

Waterproof screwcaps

Tjæreborg Industri supplies waterproof screw caps in plastic for protection of spindles and drain-/ went valves on preinsulated district heating valves.

The waterproof screw caps are available in 3 types and protect the district heating valves against rainwater, moisture, salt and dirt, including brake dust, which means easier operation and longer service life.



Waterproof screwcap and frame, type 1

When there is a risk of high standing groundwater, the waterproof screw caps have great advantage, because you avoid groundwater from entering the district heating valve.

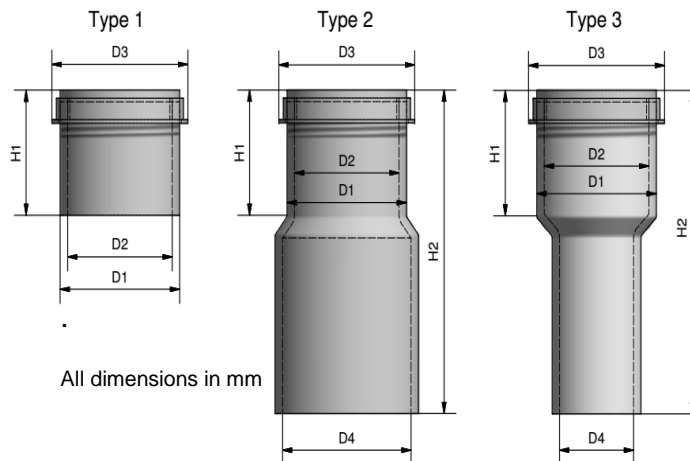

All dimensions in mm

- D1 = Outer diameter frame
- D2 = Internal illumination frame
- D3 = Outer diameter lid
- D4 = internal illumination extension tube
- H1 = height frame + lid
- H2 = height lid + frame + extends tubing



Foto from Skafte A/S

Type1-3 D1	Type 1-3 D2	Type 1-3 D3	Type 1-3 H1
75	68	111	91
110	101	150	92
160	140	182	129
250	218	268	120
290	260	328	95
540	440	(550)	190

D4 for type 2 in according to customer request

H2 for type 2 is max. 1.500 mm

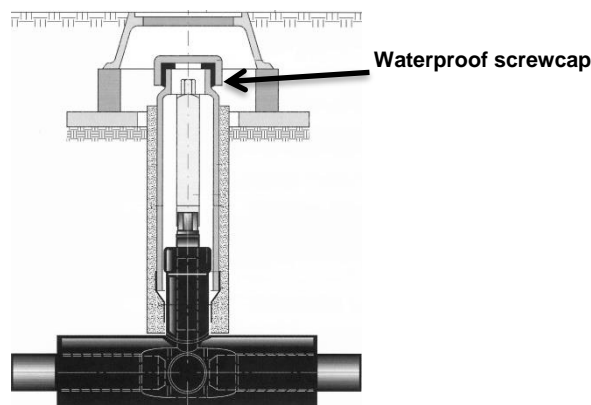
H2 for type 3 in according to customer request

Type 3 D4	Type 3 D1	Type 3 D1	Type 3 D1	Type 3 D1
119	160	250	290	540
134	160	250	290	540
153	x	250	290	540
172	x	250	290	540
192	x	250	290	540
217	x	250	290	540
241	x	x	290	540

Frame or extension tube can be fitted with shrink sleeve or with double sealed shrink muff, mastic and shrink cuff.

We would be happy to help with solutions and designs.

Updated 29.08.2019/LHo